

Base Mount Series Lights

The above lights are designed for use on sail and power driven vessels under 20 meters (65.6 ft.) in length operating on a nominal 12 volt, 24 volt or 32 volt system. In order to comply with '72 COLREGS and the U.S. Inland Rules, the following must be adhered to:

MOUNTING INFORMATION

Read all instructions before proceeding

For proper light selection, positioning and configuration, refer to the A.B.Y.C. Standard A-16*, the '72 COLREGS* and the U.S. Inland Rules*. The Bi-Color, Red side lights and all 32 volt applications are for Replacement Use Only.

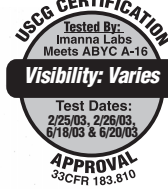
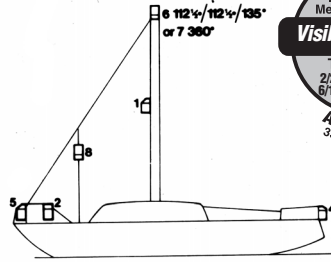

Light	Visibility	Type
0200 BB*	2nm	Bi-Color
0200 GRB	2nm/2nm	Green/Red All Rnd
0200 MAB	3nm/2nm	Mast/Wht All Rnd
0200 MB	3nm	Masthead
0200 PB*	2nm	Red Side
0200 SDB	2nm	Green Side
0200 SGB	2nm	Green All Rnd
0200 SNB	2nm	Stern
0200 SRB	2nm	Red All Rnd
0200 SWB	2nm	White All Rnd
0200 TAB**	2nm/2nm	TriColor/All Rnd
0200 TB*	2nm	Tri Color
0200 TWB	2nm	Towing

Consider the placement of the light to give:

- Correct positioning of the light on the boat and
- The most convenient positions for cleaning and bulb changing.

To ensure the correct optical performance of the lights:

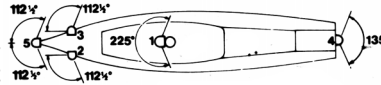

- Mount the red (port) and green (starboard) sidelights accurately vertical in the same thwartship plane and at the same height above the waterline at least one meter below the masthead light with the symbol (⇨) parallel with the boat centerline and pointing to the bow. If a bicolor light is used, mount on the centerline of the vessel at the bow at right angles to the centerline and at least 1 meter below the masthead light.
- Mount the white masthead light vertical on the centerline clear of all other lights with the symbol (⇨) parallel with the boat centerline pointing to the bow. On boats less than 12 meters, mount at least 1 meter above the sidelights. On boats 12 meters and above but less than 20 meters, mount no less than 2.5 meters above the gunwale, and at least 1 meter above the sidelights.
- Mount the white stern light vertical on the centerline and high enough not to be obscured by a following sea, with the symbol (⇨) parallel with the boat centerline pointing to the bow.
- Mount the tricolor light on the mast top with the symbol (⇨) parallel with the boat centerline pointing to the bow. (Note: Tricolor lights are only permitted on boats under sail)

The above lights are all approved for 12V, 24V or 32V applications except where noted.

* For Replacement Use Only not certified to A-16 (2016)

** Not Approved for 24V or 32V Applications

1. Masthead	White	Bulb 25w
2. Port	Red	Bulb 25w
3. Starboard	Green	Bulb 25w
4. Stern	White	Bulb 10w
5. Bicolor	Red/Grn	Bulb 25w
6. Tricolor	Red/Grn/Wht	Bulb 25w
7. Anchor (Mast Top)†	White	Bulb 10w
8. Anchor (Halyard)†	White	Bulb 10w

†. Signal White

Base Mount Installation

- Strip cable outer insulation to required length.
- Install silicone sleeves. These are provided as protection against high internal temperature.
- Thread cable through gland.
- Mount base (using #10 screws) with symbols (⇨) parallel with boat centerline.
- Tighten gland.
- Connect cables.
- Install bulb at correct voltage and wattage, note staggered mounting pins.
- Install lens. Turn clockwise firmly to stop.

Mounting holes can also be used to obtain correct alignment. Mount tricolor, masthead and stern lights with holes at right angles to boat centerline. Mount sidelights with holes parallel to boat centerline.

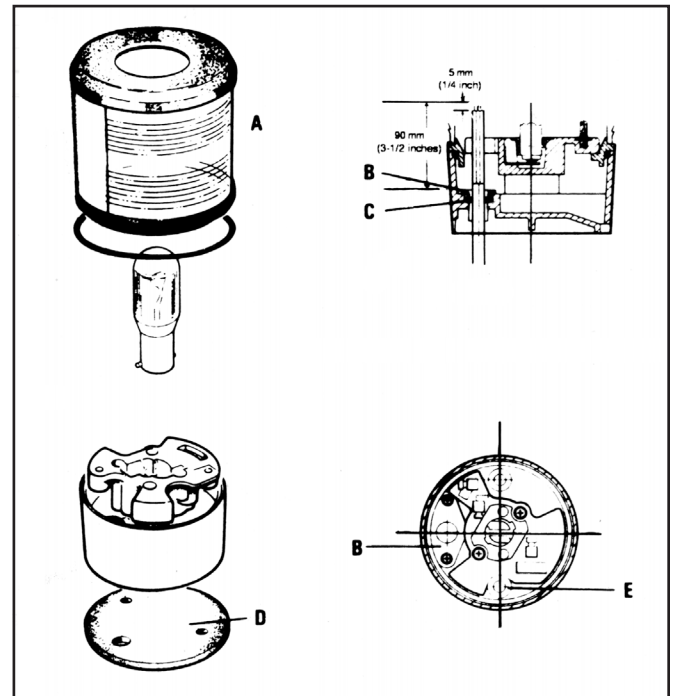

Base Mount Light Diagram

A	B	C	D	E
Lens	Cable Gland	Cable Grommet	Base Gasket	2 Mounting holes for #10 screws 2-1/8" center to center

Electrical Connections

Attach supply connections to the light, making sure to wire in accordance with both A.B.Y.C. Standard E-11* and U.S. Coast Guard Safety Standards for Boat Electrical Systems (33 CFR 183)*.

Always use cable of sufficient size to ensure total voltage drop is less than 0.5 volt for a nominal 12 volt installation (1 volt drop with 24 volt installations). Recommended minimum cable size 1.5mm² (No. 16 AWG.).

Bulbs - Use only PERKO replacement bulbs as shown to the right.

Cleaning: Use only fresh water and mild detergents to clean.

* The above referenced Standards can be obtained from.

- American Boat & Yacht Council, Inc
613 Third Street, Suite 10
Annapolis, MD 21403
- U.S. Coast Guard
Washington D.C. 20593
(or your local C.G. office)

Removing and installing the lens

A) Molded mark or Red/Green lens joint.
B) Rotate clockwise to install.
C) Rotate counter-clockwise to remove.

Bulb	Part Numbers
12V 10 Watt	037512V10W
12V 25 Watt	037512V25W
24V 10 Watt	037524V10W
24V 25 Watt	037524V25W
32V 10 Watt	037532V10W
32V 25 Watt	037532V25W